

# Onsen

## RECESS BOX FOR ONSEN WATER HEATERS

Models : ONHW26NG50  
ONHW26NG60  
ONHW26LPG50  
ONHW26LPG60

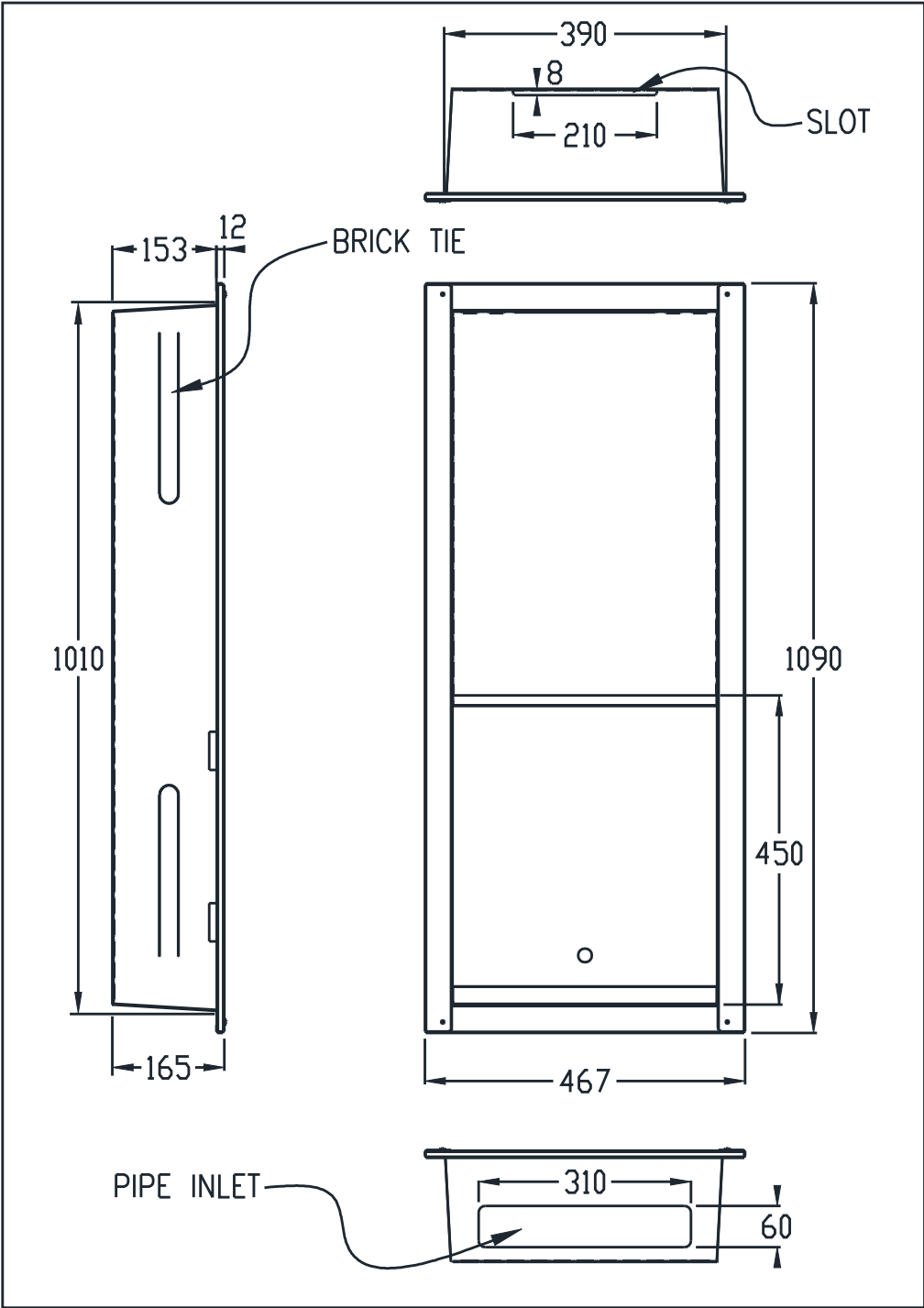

**! IMPORTANT!** Before installing your water heater, copy the model number and serial number from the product label located on the side of the water heater to your Onsen water heater user manual for future reference.

## 1. Preparing the Recess Box for Installation

- Using a flat screwdriver, gently pry out four cover bracket stubs from the side walls as shown in Diagram 1.

- Then use pliers to straighten out the brackets neatly to a 90° angle. Refer to Diagrams 2 & 3.

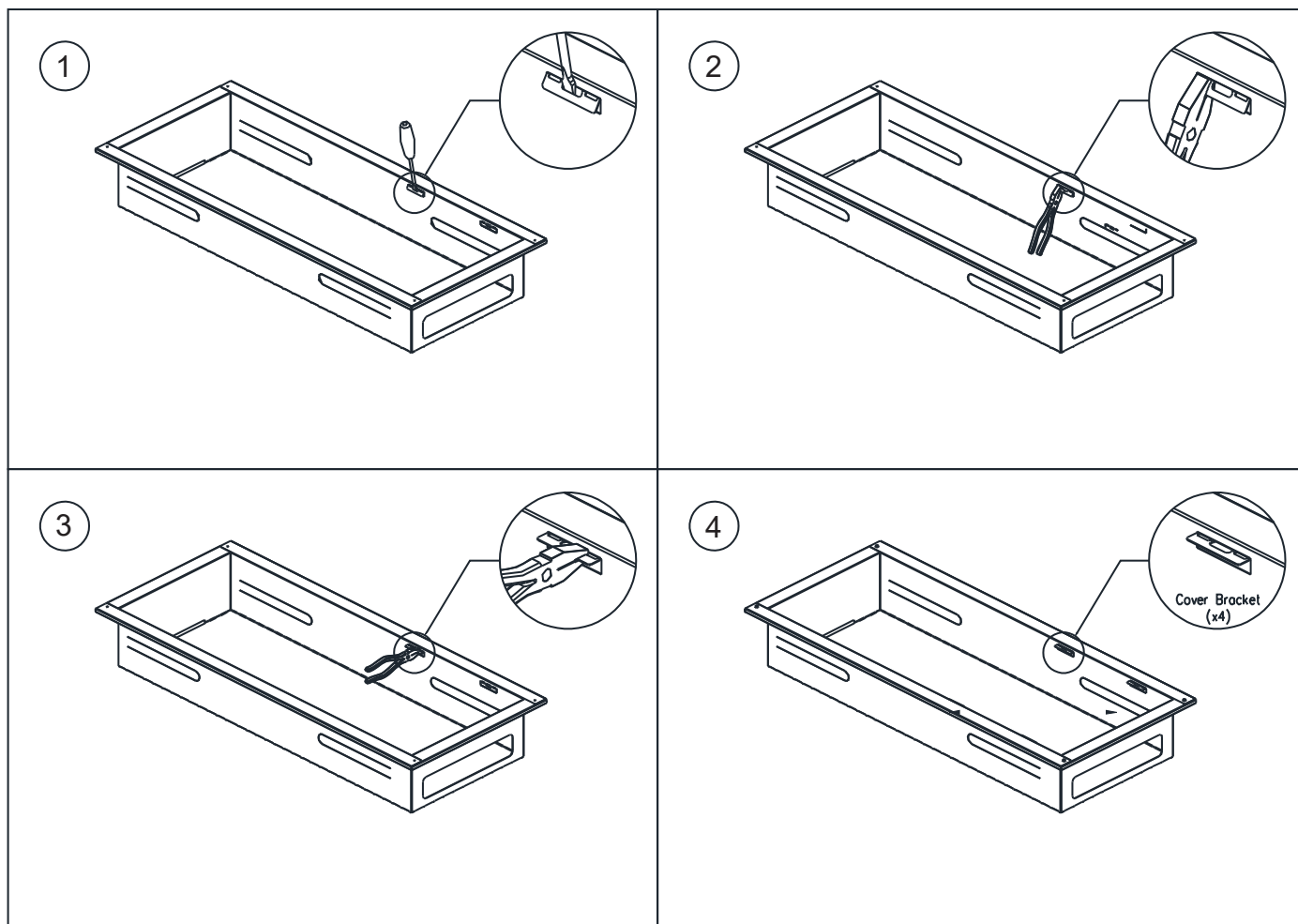

- The recess box is now ready for 26L models installation.

## 2. Installing The Recess Box

### - **Fitting the Recess Box into a new construction masonry wall.**

Bend out the 4 brick ties. Fit the recess box into the brickwork opening and anchor it to the masonry by bending the brick ties to slot into the masonry joints and using mortar to secure. Check that the box is level and allow ample time for the mortar to cure before fitting the water heater unit.

### - **Fitting the Recess Box into an existing wall.**

Prepare an opening in the wall with a cavity size of : H-1015mm x W-395mm x D-158mm.

Place box into cavity and drill out holes at required fixture points and use appropriate fasteners to secure firmly into position.

**⚠ IMPORTANT! Ensure that the pipe inlet cutout is facing down when placing in position.**

## 3. Mounting the Water Heater

- Once the recess box has been fitted onto the wall, mount the 26L water heater into the recess box by following the instructions below.

-Carefully insert the water heater into the recess box and push upwards so that the water heater upper mounting bracket goes into the 210mm x 8mm slot located at the top of the recess box.

Refer to Diagrams 5 - 7.

-Then use the mounting screws provided with your water heater to secure to the wall. (The water heater unit is heavy when filled with water and it is advisable to install wooden batons along the screw locations if necessary.) Refer to Diagram 8.

-Install all gas and water piping according to the instructions in your water heater user manual. Check for gas and water leaks. Then test and check the operation of the water heater.

-Once all the above works have been completed, for 26L models, fit the cover to conceal the pipework. To put on the cover panel, first tilt the cover slightly and insert underneath water heater front panel flange and then carefully adjust and position the cover to insert its hooks (x4) into their respective slots on the brackets on the recess box side walls.

Refer to Diagrams 9 & 10.

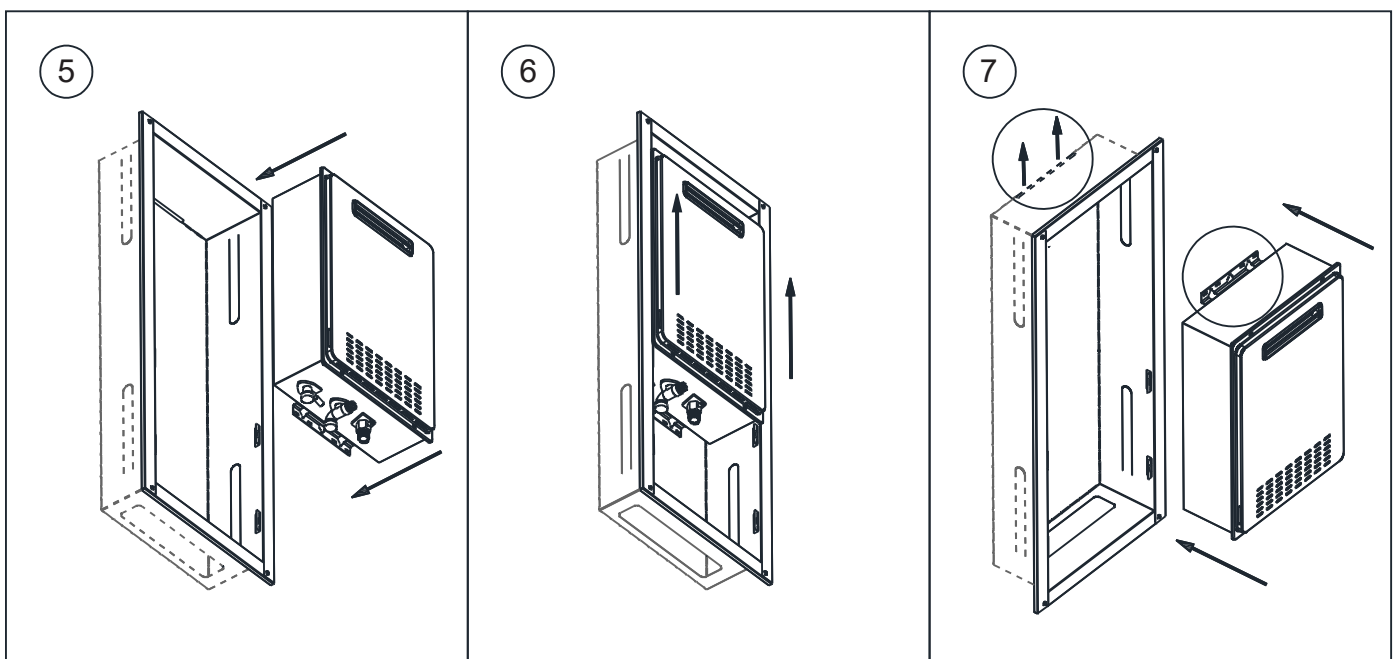

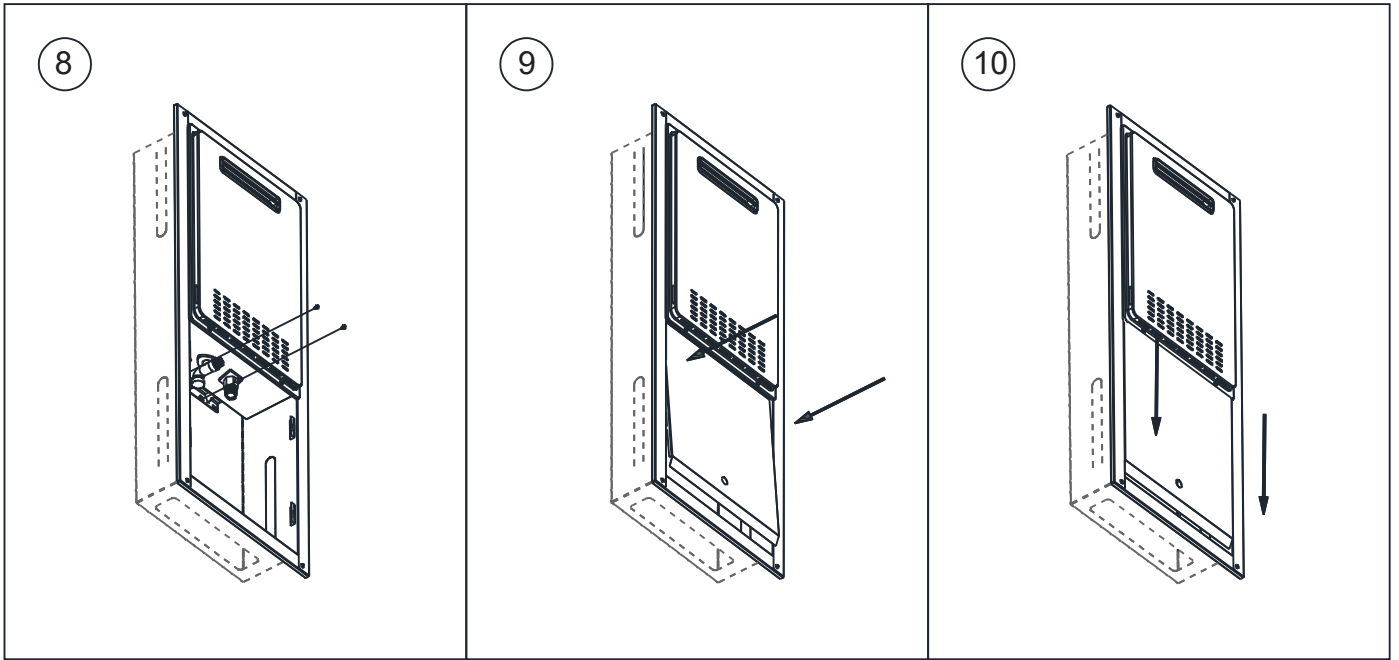

**!** **IMPORTANT!** Use a weatherproof electrical socket if necessary and weatherproof the recess box if required by using suitable sealant along the external joints and around the pipework.

Distributed by:  
SHINDA AUSTRALIA PTY LTD  
TEL : 1300 358 770 FAX:(02)9773 7399